

## Leading the Fast Tracking

By Darrell Glen Stiffler, PMP

There has been confusion when the terms *fast tracking* and *lead* are illustrated. This white paper will present several illustrations and my preference regarding their illustration. These are my opinions and some may not agree. The terms “fast tracking” and “lead” in this paper are in reference to network diagrams, activity sequencing and critical path calculation used in the Guide to the Project Management Body of Knowledge (*PMBOK<sup>®</sup> Guide*) 4<sup>th</sup> edition. The illustrations in the *PMBOK<sup>®</sup> Guide* of these two terms are as ambiguous as those on what a node should look like. In the *PMBOK<sup>®</sup> Guide* on page 21, it reads:

- “An overlapping relationship, where the phase starts prior to completion of the previous one (see Figure 2-5). This can sometimes be applied as an example of the schedule compression technique called fast tracking. Overlapping phases may increase risk and can result in rework if a subsequent phase progresses before accurate information is available from the previous phase.”

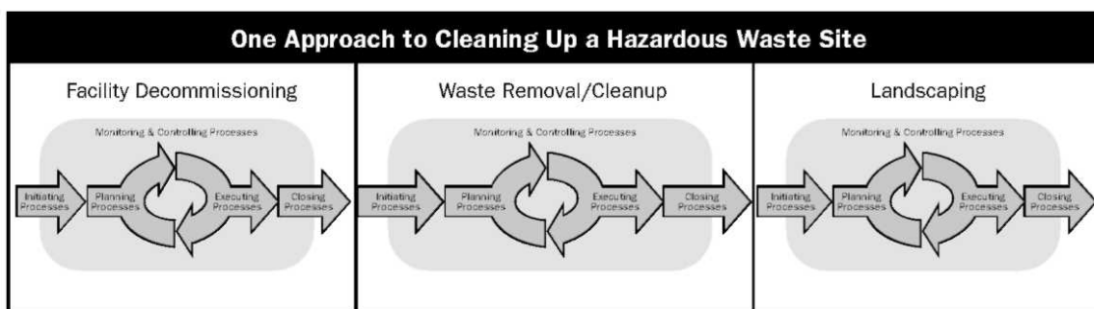
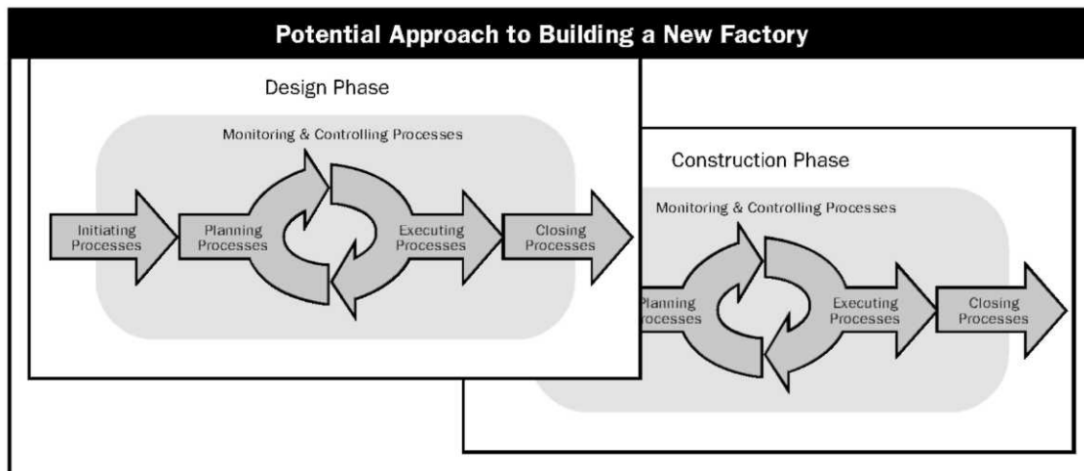

Figure 2-4. Example of a Three-Phase Project Figure



**Figure 2-5. Example of a Project with Overlapping Phases**

The above figures are found in *PMBOK® Guide* references. They are the only depiction of either lead or fast tracking in the *PMBOK® Guide*. Fast tracking is referenced on page 157 in the *PMBOK® Guide*, which states:

- “Fast tracking: A schedule compression technique in which phases or activities normally performed in sequence are performed in parallel. An example is constructing the foundation for a building before completing all of the architectural drawings. Fast tracking may result in rework and increased risk. Fast tracking only works if activities can be overlapped to shorten the duration.”

The Glossary in the *PMBOK® Guide* gives the definition for *lead* as:

- “A modification of a logical relationship that allows an acceleration of the successor activity. For example, in a finish-to-start dependency with a ten-day lead, the successor activity can start ten days before the predecessor activity has finished. A negative lead is equivalent to a positive lag.”

Now we know how the *PMBOK® Guide* defines these terms, and I am assuming you are as confused as I am at this point. In my career as a project manager and an instructor, I have seen a couple of approaches. I hope to illustrate the two approaches. Illustration 1: Original Finish to Start Path shows a network diagram with finish-to-start relationships with no compression attempted.

Illustration 1: Original Finish to Start Path

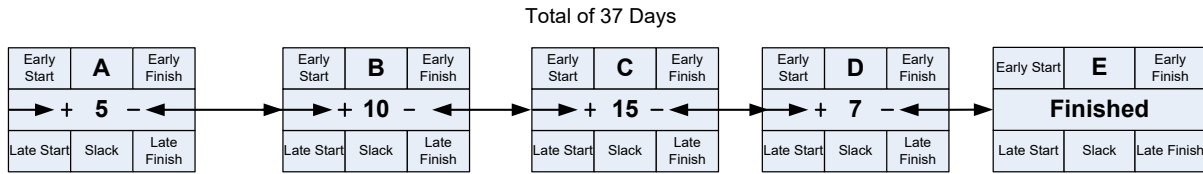

Illustrations 2 and 3 are different illustrations that I have seen for both *fast tracking* and *lead*.

Illustration 2: "Fast Tracking" or "Lead"

The Original Time Line was 37 days.  
By using this approach of sequencing the time line has been reduced to a total of 25 Days

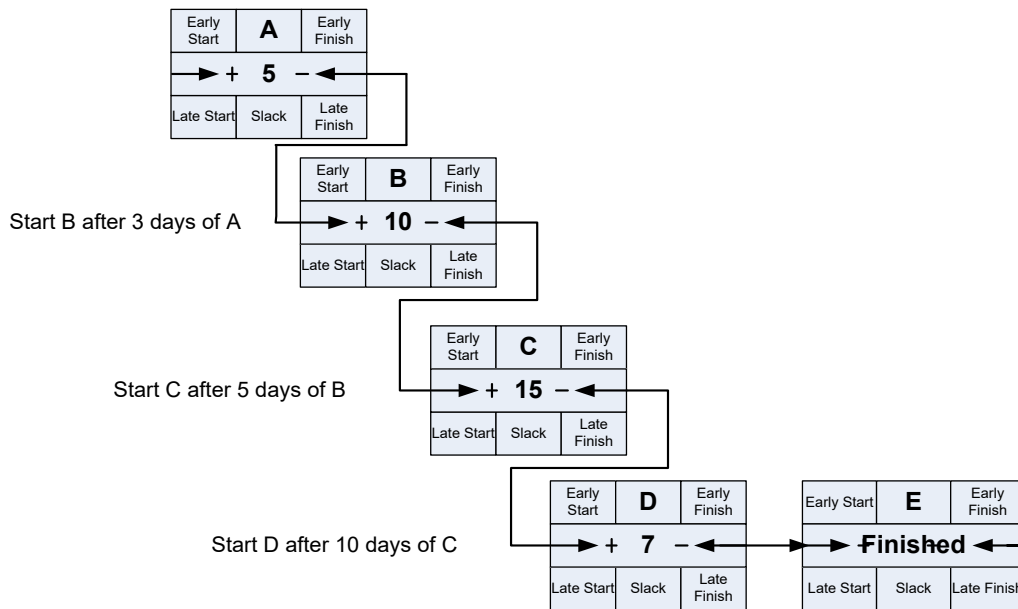
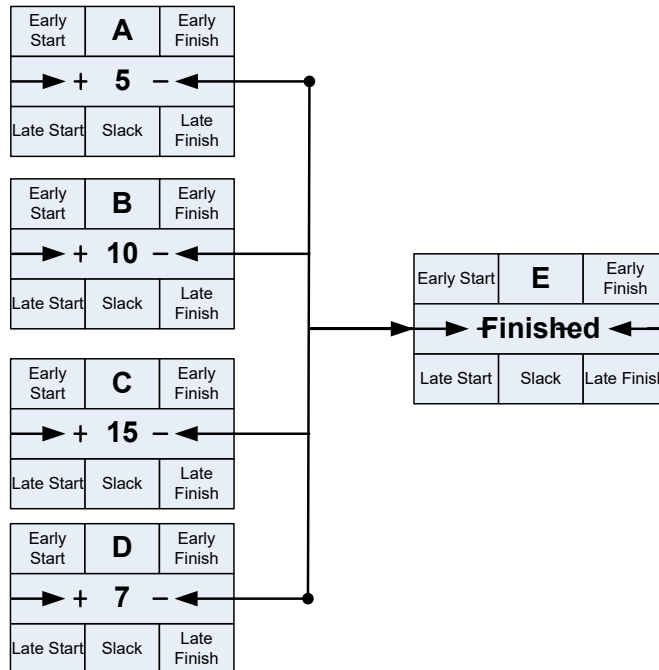

Illustration 3: “Fast Tracking” or “Lead”

The Original Time Line was 37 days.  
 By using this approach of sequencing the time line has  
 been reduced to a total of 15 Days



Under Illustration 2, you indeed get overlapping, and parallel performance –as the *PMBOK® Guide* states– is required. The path can be compressed substantially based upon the number of days the project manager wishes to overlap the activities. I refer to this as getting a jump-start on an activity. However, Illustration 3 also depicts overlapping and parallel performance relationships. It has a shorter duration than Illustration 1 because it converts the relationships between the activities to start-to-start relationships.

So, which is correct? I think the answer lies in the Enterprise Environmental Factors and the Organizational Process Assets of the performing organization. I think either one could be correct. The point is to be aware of each and to be aware of the ambiguity of the *PMBOK® Guide*.

My preference would be Illustration 2 for the term *lead* and Illustration 3 for the term *fast tracking*. If the project requires doing rework, and if you have enough resources, you will probably use Illustration 3. This approach will give the project a shorter duration.

## About the Author

Darrell G. Stiffler, PMP is a professional with over 20 years of operations and information technology management experience in a variety of industries and areas including IT, insurance, health care, financial services, construction, retail, software development and maintenance, manufacturing, and transportation. He has consulted with both large and small organizations. He has a military background and currently applies his years of experience to train and consult others in project management and ITIL professional development. He received his PMP designation in September of 1999, a time when there were only 12,000 PMPs in the world. He is also certified in ITIL Foundations v2 and v3.

## About Forward Momentum, LLC

Forward Momentum, LLC is a woman-owned small business (WOSB) specializing in project management training/consulting, instructional design services, and custom learning solutions for commercial, government, and non-profit organizations. Since 2000, Forward Momentum has grown to develop, manage, and deliver award-winning Instructor-Led Training (ILT), virtual Instructor-Led Training (vILT), eLearning, and blended learning programs physically on five (5) continents and virtually to all seven (7) continents. Our eLearning is rigorously tested by DHS Certified Trusted Testers for Accessibility and is Section 508 compliant.

To date, we have trained over 40,000 people, including over 6,000 on the Project Management Professional (PMP®) certification exam preparation. We co-developed the innovative blended learning PMP® exam preparation program that earned PMI's Professional Development Product of the Year award in 2007. We are a PM Training Alliance® (PMTA) Certified Training Provider (CTP), and Project Management Institute® (PMI) Global Registered Education Provider (REP).

As a boutique firm, we pride ourselves on our responsiveness and dedication to understanding your business, analyzing your learning and development needs, and driving efficiencies and growth. Visit [www.forwardmomentum.net](http://www.forwardmomentum.net) or email [dobusiness@forwardmomentum.net](mailto:dobusiness@forwardmomentum.net) to learn how our approach can optimize your learning experience, improve your processes, or empower your team.